

■Features

- High Luminous Super Flux Output
- 5 ° Standard Directivity
- UV Resistant Epoxy
- Water Clear Type

■Applications

- Green House Applications
- Red: Blue LED Iv Ratio is 8:1*

*The ratio is summarized by the photosynthesis test on Phalaenopsis and provided from plant workshop in Taiwan.

■Outline Dimension

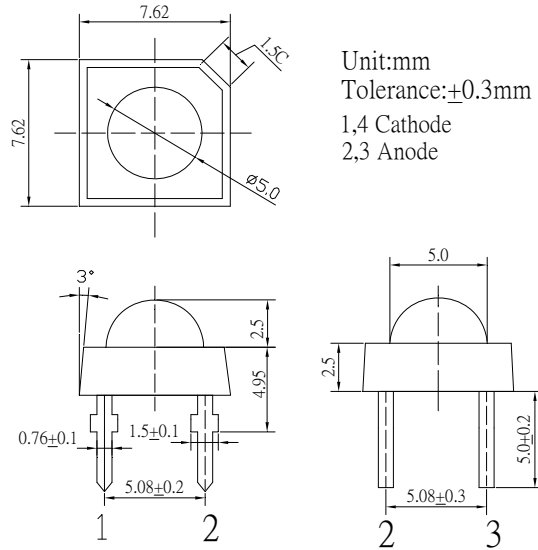

■Absolute Maximum Rating

(Ta=25°C)

Item	Symbol	Value	Unit
DC Forward Current	I _F	70	mA
Pulse Forward Current#	I _{FP}	120	mA
Reverse Voltage	V _R	5	V
Power Dissipation	P _D	182	mW
Operating Temperature	T _{opr}	-30 ~ +85	°C
Storage Temperature	T _{stg}	-40 ~ +100	°C
Lead Soldering Temperature	T _{sol}	260°C/5sec	-

#Pulse width Max.10ms Duty ratio max 1/10

■Directivity

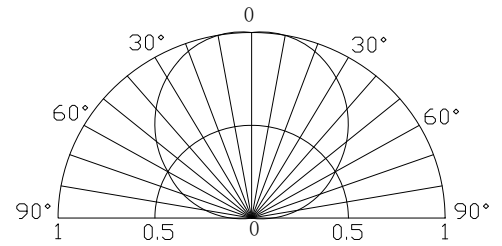

■Electrical -Optical Characteristics

(Ta=25°C)

Item	Symbol	Condition	Min.	Typ.	Max.	Unit
DC Forward Voltage	V _F	I _F =70mA	2.0	2.3	2.6	V
DC Reverse Current	I _R	V _R =5V	-	-	10	μA
Peak Wavelength*	λ _p	I _F =70mA	650	660	670	nm
Luminous Intensity*	I _v	I _F =70mA	2180	3000	-	mcd
50% Power Angle	2θ _{1/2}	I _F =70mA	-	120	-	deg

*1 Tolerance of measurements of peak wavelength is ±1nm

*2 Tolerance of measurements of luminous intensity is ±15%

*3 Tolerance of measurements of forward voltage is ±0.1V

■Maximum Forward Current

