

### ■Features

- High Radiant Power LEDs
- 5mm Standard Directivity
- UV Resistant Epoxy
- Pale Red Brown Transparent Type

### ■Applications

- IrDA
- Encoder
- Data Communication

### ■Outline Dimension

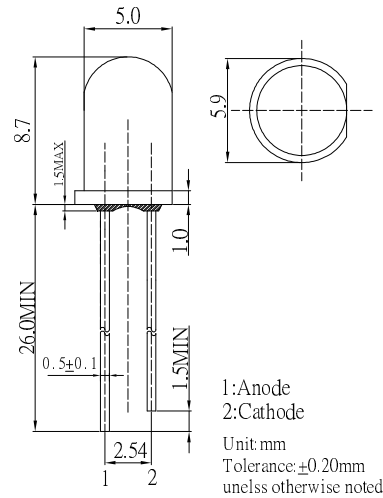

### ■Absolute Maximum Rating

(Ta=25°C)

Item	Symbol	Value	Unit
DC Forward Current	I <sub>F</sub>	100	mA
Pulse Forward Current#	I <sub>FP</sub>	1000	mA
Reverse Voltage	V <sub>R</sub>	5	V
Power Dissipation	P <sub>D</sub>	180	mW
Operating Temperature	T <sub>opr</sub>	-30 ~ +85	°C
Storage Temperature	T <sub>stg</sub>	-40 ~ +100	°C
Lead Soldering Temperature	T <sub>sol</sub>	260°C/5sec	-

#Pulse width Max.10ms Duty ratio max 1/10

### ■Directivity

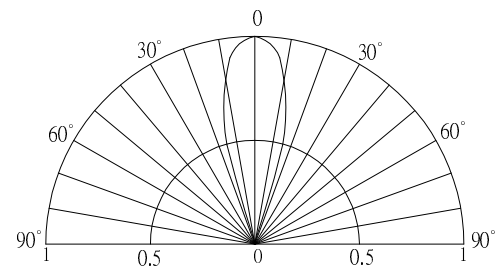

### ■Electrical -Optical Characteristics

(Ta=25°C)

Item	Symbol	Condition	Min.	Typ.	Max.	Unit
DC Forward Voltage*1	V <sub>F</sub>	I <sub>F</sub> =100mA	-	1.6	1.8	V
DC Reverse Current	I <sub>R</sub>	V <sub>R</sub> =5V	-	-	10	μA
Peak Wavelength*2	λ <sub>p</sub>	I <sub>F</sub> =100mA	-	850	-	nm
Radiant Power	P <sub>o</sub>	I <sub>F</sub> =100mA	45	55	-	mW
Radiant Intensity*3	I <sub>e</sub>	I <sub>F</sub> =100mA	150	220	-	mW/Sr
50% Power Angle	2θ <sub>1/2</sub>	I <sub>F</sub> =100mA	-	30	-	deg

\*1 Tolerance of measurements of forward voltage is ±0.1V

\*2 Tolerance of measurements of peak wavelength is +1nm

\*3 Tolerance of measurements of radiant intensity is +15%