

■Features

- Bi-Color
- Super high brightness of surface mount LED
- Water Clear Flat Mold
- Compact package outline
(LxWxT) of 3.2mm x 2.7mm x 1.1mm
- Compatible to IR reflow soldering.

■Applications

- Backlighting (switches, keys, etc.)
- Marker lights (e.g. steps, exit ways, etc.)

Outline Dimension

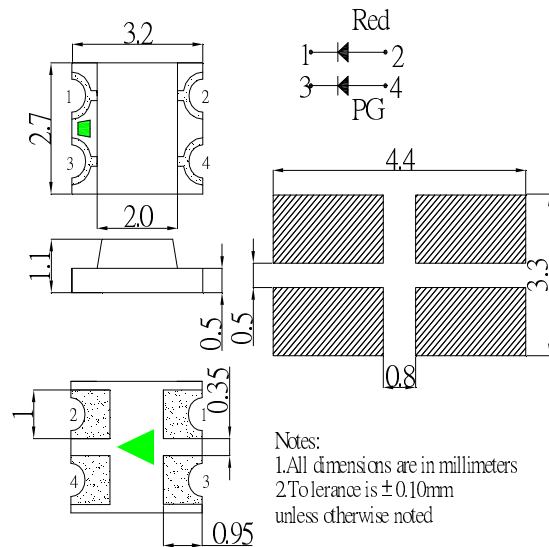

■Absolute Maximum Rating

($T_a=25^\circ\text{C}$)

Item	Symbol	Value		Unit
		HR	PG	
DC Forward Current	I_F	30	30	mA
Pulse Forward Current*	I_{FP}	100	100	mA
Reverse Voltage	V_R	5	5	V
Power Dissipation	P_D	78	108	mW
Operating Temperature	T_{opr}	-40 ~ +85		$^\circ\text{C}$
Storage Temperature	T_{stg}	-40 ~ +85		$^\circ\text{C}$
Lead Soldering Temperature	T_{sol}	260 $^\circ\text{C}$ /10sec		-

*Pulse width Max 0.1ms, Duty ratio max 1/10

■Directivity

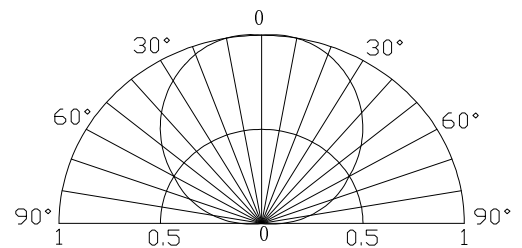

■Electrical -Optical Characteristics

($T_a=25^\circ\text{C}$)

Part Number	Color			V_F (V)			I_R (μA)	I_v (mcd)			λ_D (nm)			$2\theta_{1/2}$ (deg)
				Min.	Typ.	Max.	Max.	Min.	Typ.	Max.	Min.	Typ.	Max.	Typ.
				$I_F=20\text{mA}$			$V_R=5\text{V}$	$I_F=20\text{mA}$						
OSRP206C1C	Red	HR	■	1.8	2.1	2.6	10	80	100	150	620	625	630	120
	Pure Green	PG	■	2.6	3.1	3.6	10	200	350	500	515	525	530	120

*1 Tolerance of measurements of dominant wavelength is $\pm 1\text{nm}$

*2 Tolerance of measurements of luminous intensity is $\pm 15\%$

*3 Tolerance of measurements of forward voltage is $\pm 0.1\text{V}$

■ Soldering Conditions

Reflow Soldering		Hand Soldering	
Pre-Heat	180 ~ 200°C	Temperature Soldering time	350°C Max. 3 sec. Max. (one time only)
Pre-Heat Time	120 sec. Max.		
Peak temperature	260°C Max.		
Dipping Time	10 sec. Max.		
Condition	Refer to Temperature-profile		

• Reflow Soldering Condition(Lead-free Solder)

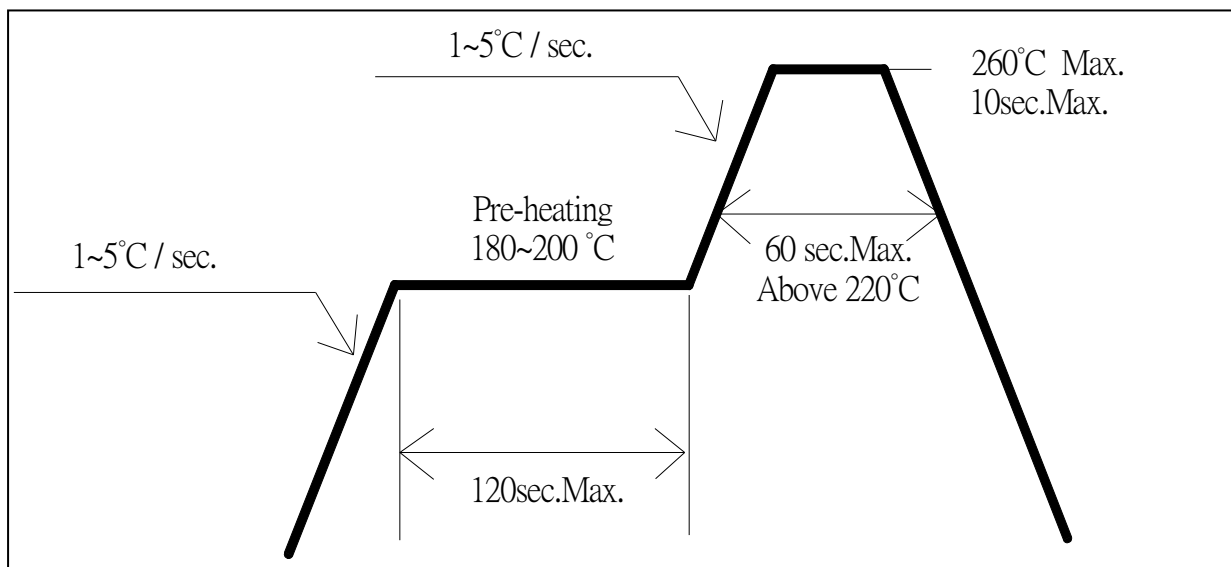

*Recommended soldering conditions vary according to the type of LED

*Although the recommended soldering conditions are specified in the above table, reflow, or hand soldering at the lowest possible temperature is desirable for the LEDs.

*A rapid-rate process is not recommended for cooling the LEDs down from the peak temperature.

• All SMD LED products are pb-free soldering available.

• Occasionally there is a brightness decrease caused by the influence of heat or ambient atmosphere during air reflow. It is recommended that the User use the nitrogen reflow method.

• Repairing should not be done after the LEDs have been soldered. When repairing is unavoidable a double-head soldering iron should be used. It should be confirmed beforehand whether the characteristics of the LEDs will or will not be damaged by repairing.

• Reflow soldering should not be done more than two times.

• When soldering, do not put stress on the LEDs during heating.

• After soldering, do not warp the circuit board.

■ **Cautions:**

1. After open the package, the LED's floor life is 1 year under 30°C or less and 60%RH or less (MSL:2).
2. Heat generation must be taken into design consideration when using the LED.
3. Power must be applied resistors for protection, over current would be caused the optic damage to the devices and wavelength shift.
4. Manual tip solder may cause the damage to Chip devices, so advised that heat of iron should be lower than 15W with temperature control under 5 seconds at 230-260 deg. C. (The device would be got damage in re working process, recommended under 5 seconds at 230-260 deg. C)
5. All equipment and machinery must be properly grounded. It is recommended to use a wristband or anti-electrostatic glove when handing the LED.
6. Use IPA as a solvent for cleaning the LED. The other solvent may dissolve the LED package and the epoxy, Ultrasonic cleaning should not be done.
7. Damaged LED will show unusual characteristics such as leak current remarkably increase, turn-on voltage becomes lower and the LED get unlight at low current.
8. OPTOSUPPLY will not do 4M change without advance consultation.