

**■Features**

- High Radiant Power PLCC2 Top SMD LEDs
- 3.5x2.8x1.9mm Standard Directivity
- Superior Weather-resistance
- UV Resistant Silicone
- Water Clear Type

**■Applications**

- Automatic Control System
- Photo Detector
- Computer I/O Peripheral

**■Outline Dimension**

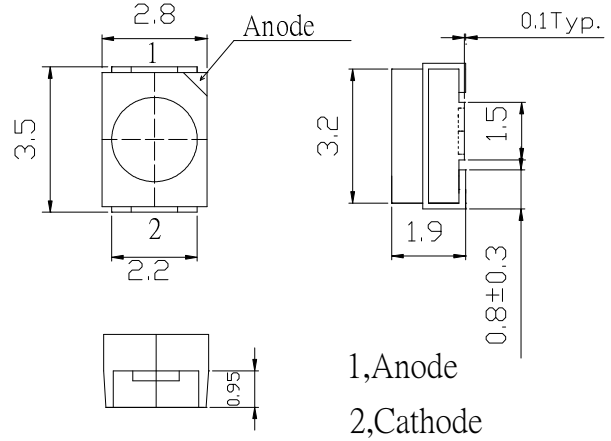

**■Absolute Maximum Rating**

(Ta=25°C)

Item	Symbol	Value	Unit
DC Forward Current	I <sub>F</sub>	100	mA
Pulse Forward Current*	I <sub>FP</sub>	200	mA
Reverse Voltage	V <sub>R</sub>	5	V
Power Dissipation	P <sub>D</sub>	200	mW
Operating Temperature	Topr	-30 ~ +85	°C
Storage Temperature	Tstg	-40~ +100	°C
Lead Soldering Temperature	Tsol	260°C/5sec	-

\*Pulse width Max.10ms Duty ratio max 1/10

**■Directivity**

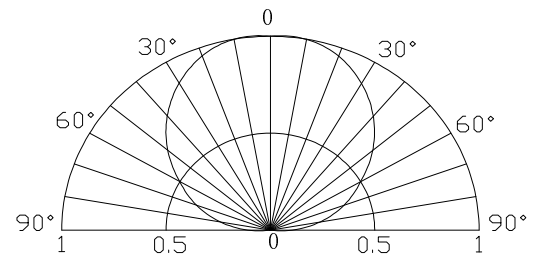

**■Electrical -Optical Characteristics**

(Ta=25°C)

Item	Symbol	Condition	Min.	Typ.	Max.	Unit
DC Forward Voltage	V <sub>F</sub>	I <sub>F</sub> =100mA	-	1.6	2.0	V
DC Reverse Current	I <sub>R</sub>	V <sub>R</sub> =5V	-	-	10	μA
Peak Wavelength	λ <sub>p</sub>	I <sub>F</sub> =100mA	886	880	892	nm
Radiant Intensity	I <sub>e</sub>	I <sub>F</sub> =100mA	-	45	-	mW/Sr
50% Power Angle	2θ <sub>1/2</sub>	I <sub>F</sub> =100mA	-	120	-	deg

\*1 Tolerance of measurements of peak wavelength is ±1nm

\*2 Tolerance of measurements of radiant intensity is ±15%

\*3 Tolerance of measurements of forward voltage is ±0.1V