

■Features

- High Luminous Super Flux Output
- 5 ° Standard Directivity
- Long Lifetime Operation
- Low Thermal Resistance
- Superior Weather-Resistance
- UV Resistant Epoxy
- Water Clear Type

■Applications

- Interior and exterior automotive lighting (e.g. dashboard backlighting etc.)
- Backlighting (Illuminated advertising, general lighting, etc)
- Decorative Lighting
- Other Lighting

■Outline Dimension

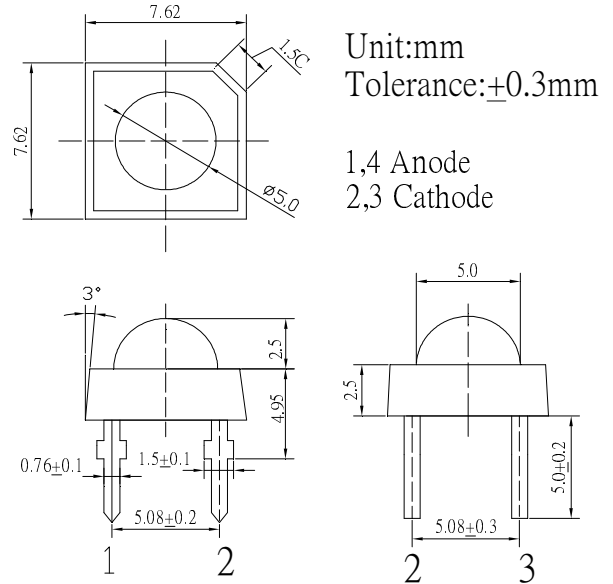

■Absolute Maximum Rating

(Ta=25°C)

Item	Symbol	Value	Unit
DC Forward Current	I _F	50	mA
Pulse Forward Current*	I _{FP}	120	mA
Reverse Voltage	V _R	5	V
Power Dissipation	P _D	190	mW
Operating Temperature	Topr	-30 ~ +85	°C
Storage Temperature	Tstg	-40 ~ +100	°C
Lead Soldering Temperature	Tsol	260°C / 5sec	-

*Pulse width Max.10ms , Duty ratio max 1/10

■Directivity

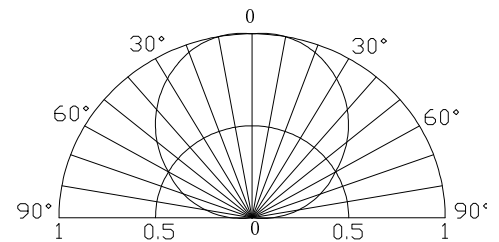

■Electrical -Optical Characteristics

(Ta=25°C)

Item	Symbol	Condition	Min.	Typ.	Max.	Unit
DC Forward Voltage	V _F	I _F =50mA	2.9	3.1	3.8	V
DC Reverse Current	I _R	V _R =5V	-	-	10	µA
Luminous Intensity*	I _v	I _F =50mA	1100	1400	-	mcd
Chromaticity Coordinates*	x	I _F =50mA	-	0.45	-	
	y	I _F =50mA	-	0.17	-	
50% Power Angle	2θ _{1/2}	I _F =50mA	-	120	-	deg

*1 Tolerance of measurements of chromaticity coordinate is ±10%

*2 Tolerance of measurements of luminous intensity is ±15%

*3 Tolerance of measurements of forward voltage is ±0.1V